

SALES DRAWING

SALES DRAWING

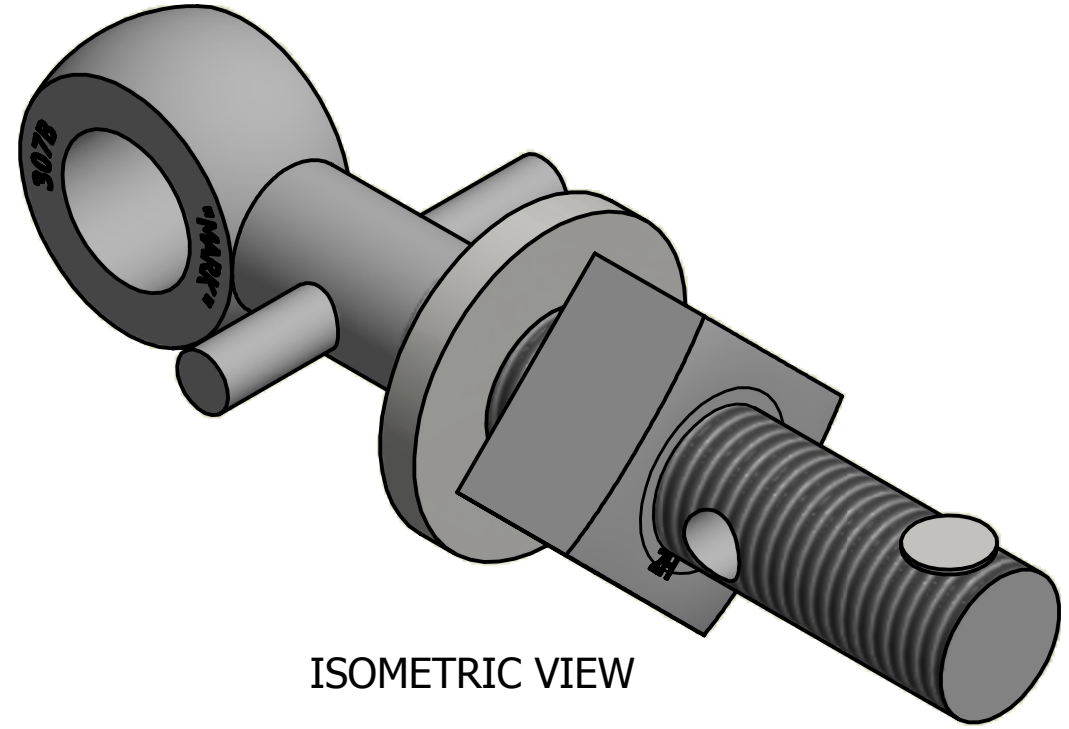

ISOMETRIC VIEW

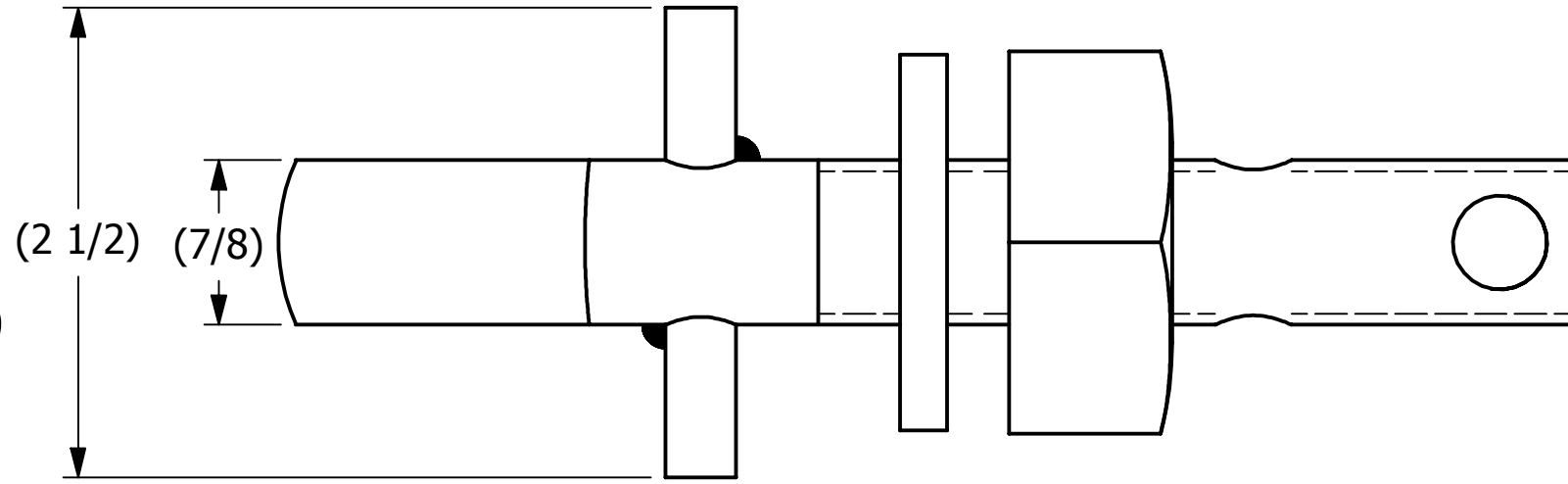
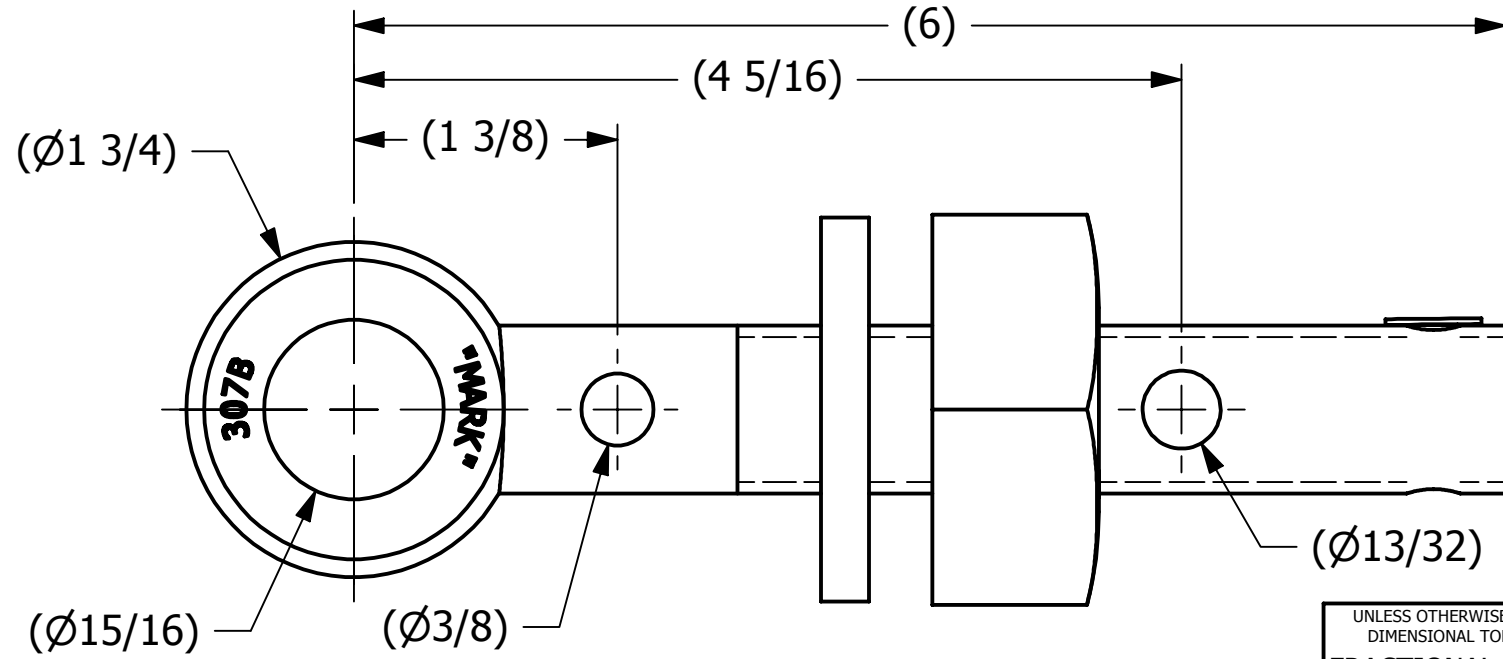

REV	BY	DATE	DESCRIPTION
E	BRG	12-6-08	UPDATED EYEBOLT MATERIAL
D	CHL	6-10-02	CHANGED MATERIAL OF WASH78T TO CS
C	CHL	11-26-01	REPLACED SN14S WITH A16204
B	FOD	5-22-00	CHANGED ITEM #3 DESCRIPTION
A	FOD	6-3-99	ITEM #1 WAS EBR786HP AND UPDATED DRAWING WITH NEW STANDARDS

<small>UNLESS OTHERWISE SPECIFIED DIMENSIONAL TOLERANCES</small> FRACTIONAL: ±1/16 X.XX: ±.03 X.XXX: ±.015 ANGULAR: ±1° <small>DEBURR ALL SHARP EDGES. ALL MACHINED SURFACES TO HAVE A 125 RMS FINISH UNLESS NOTED OTHERWISE.</small> THIRD ANGLE PROJECTION	DRAWN BY:	TJN
	CHECKED BY:	
	PROTOTYPE BY:	TJN
	PROTOTYPE DATE:	
	APPROVED FOR PRODUCTION BY:	TJN
	PRODUCTION DATE:	2/5/1993

<b>SALCO PRODUCTS, INC.</b>		
PART NAME: EYEBOLT ASSEMBLY 7/8"X6"		
MATERIAL: CARBON STEEL		
PROJECT #:	SHEET #: 1 OF 1	SCALE: 1:1
DRAWING #: B5381	PART #: EB786HAP	

THIS PRINT, PROPERTY OF SALCO PRODUCTS INC., CONTAINS PROPRIETARY INFORMATION AND MUST NOT BE COPIED, REPRODUCED, OR USED DETRIMENTALLY TO OUR INTEREST.